

# USER'S GUIDE

## Trim-A-Gutter™

**Gutter Hood Tools & Accessories**  
**New Construction and Retrofit**  
**Now includes 5" & 6" inch gutter installations**

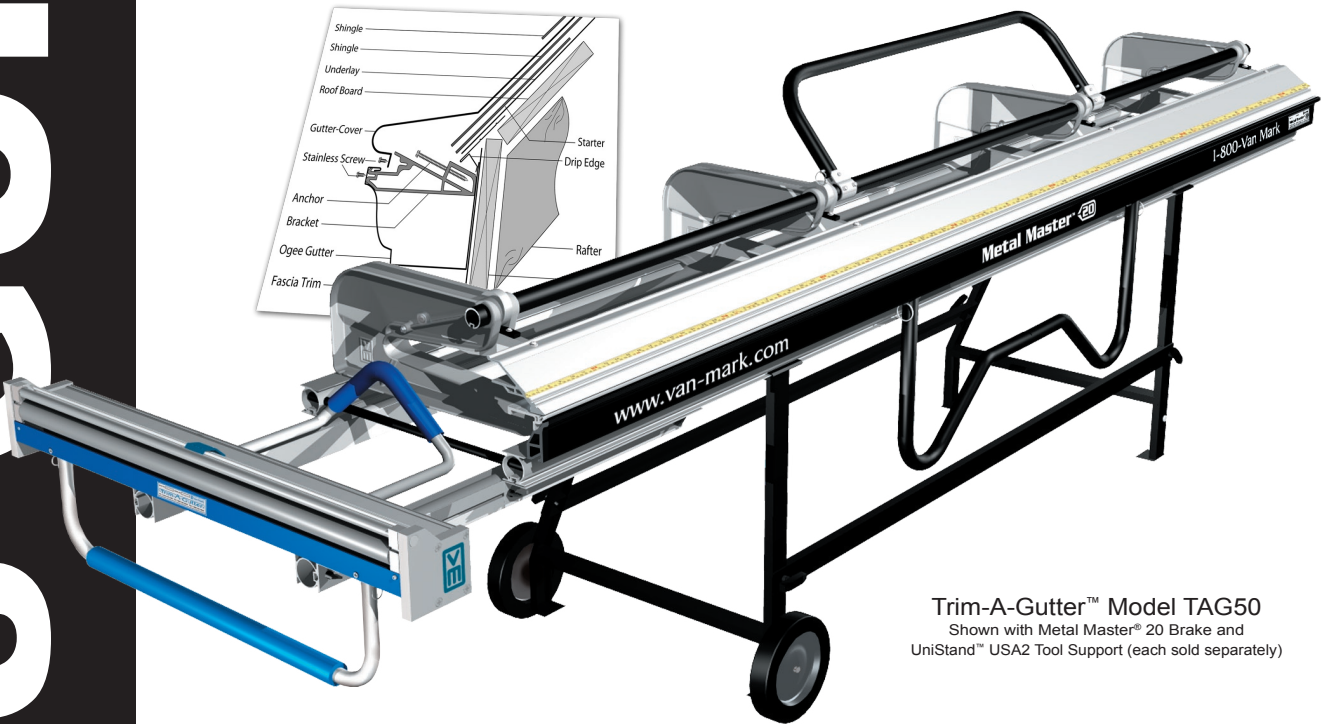

Trim-A-Gutter™ Model TAG50  
 Shown with Metal Master® 20 Brake and  
 UniStand™ USA2 Tool Support (each sold separately)



Trim-A-Gutter™ Model TAG50  
 Shown with UniLegs™ UNL1 (sold separately)

Save This Guide  
 For Reference!

### Table of Contents

Tool Setup, Bending Brakes.....	2
Tool Setup, Metal Master® 20.....	3
Tool Setup, With Unilegs™.....	4
Forming Gutter-Hood.....	4
Existing Gutter Installation.....	4
Forming End-Caps, Miters, & Valleys.....	5
Template.....	6
New Gutter Installation.....	6
Example Profiles/Uses.....	7
Care & Maintenance.....	7
Parts List.....	8

Patent No's 7,500,375, 7,707,781  
 Other US and Foreign Patents Pending

Price \$10.00 US



Van Mark Web



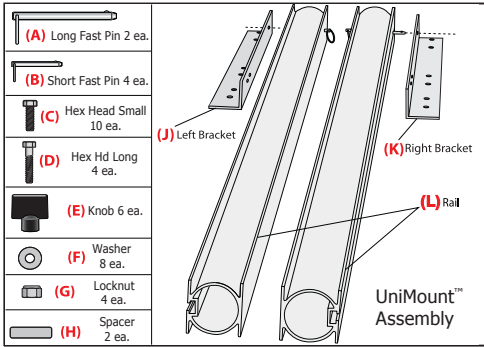

## Left Mounting Bracket (J)

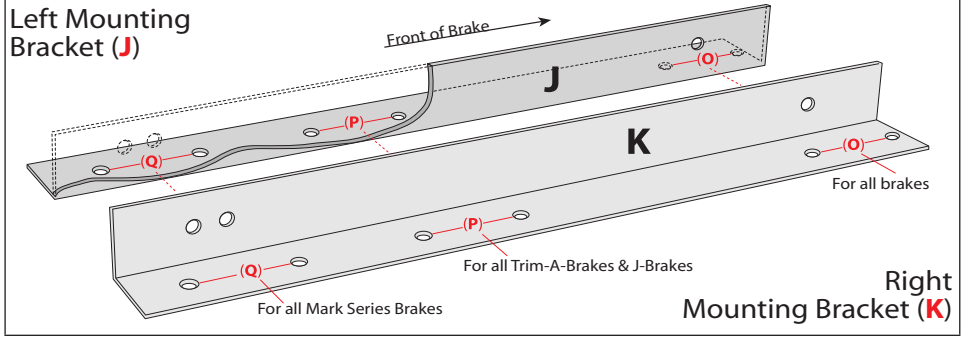

Use this diagram as a reference for parts/hardware called out in these next 2 pages, though each part may only be called out once in each step. Tools needed: Phillips screwdriver, slotted screwdriver and a 7/16 wrench, or socket wrench.

Note: Whether mounting your Trim-A-Gutter™ to a Van Mark brake or mounting on optional UniLegs™ for use with any brake, knowing beforehand which holes in the mounting brackets apply to your particular Trim-A-Gutter/brake setup will save you time and effort. Please look over the hole locations above and determine which setup below applies to you before proceeding.

Setup Note: Determine the type of Van Mark brake you use and follow the instructions in that column to mount your new tool. For all other brakes you must purchase a set of UniLegs™ and follow steps 1-6 "Tool Setup on UniLegs" at the bottom half of page 3.

## MARK SERIES™ BRAKES

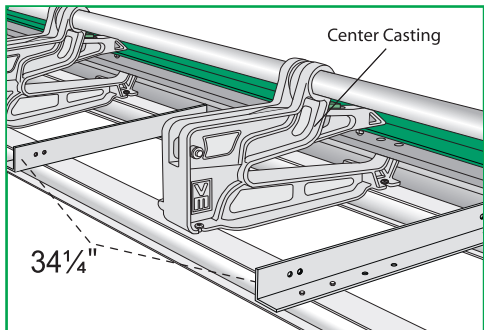

1 As seen in the mounting bracket above, use holes **O** and **Q** when mounting right bracket **K** and left bracket **J** on either side of the center casting.

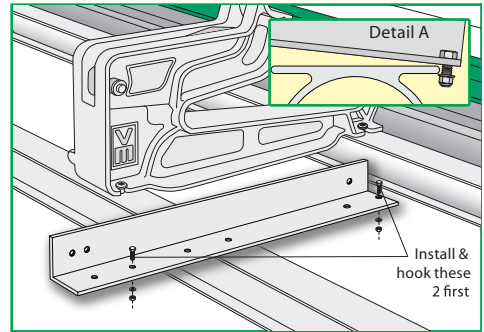

2 Insert hex head screw **C** down front hole **O** of right bracket **K**. From below, place washer **F** onto threads and start hex nut **G**. Insert hex head screw **C** down front hole **Q** of right bracket **K**. Again place washer **F** onto threads and start hex nut **G**. Place bracket **K** over rails letting washers **F** hook over rail flanges (see Detail A).

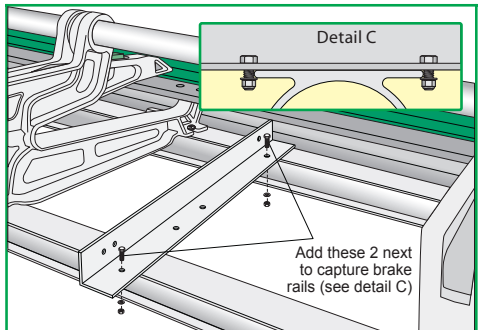

3 Insert hex head screw **C** down rear hole **O**. From below, place washer **F** onto threads and start hex nut **G**. Insert hex head screw **C** down rear hole of **Q**. Again place washer **F** onto threads and start hex nut **G**. As seen in Detail C, rail flanges should now become captured. Repeat on other side of center casting with left bracket **J** then continue to step 4, page 3.

## MARK II TRIMMASTER®

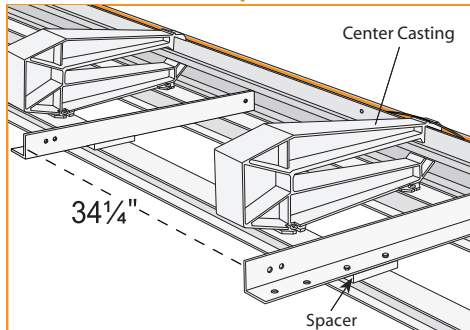

1 As seen in the mounting bracket above, use holes **O** and **P** when mounting right bracket **K** and left bracket **J** on either side of the center casting.

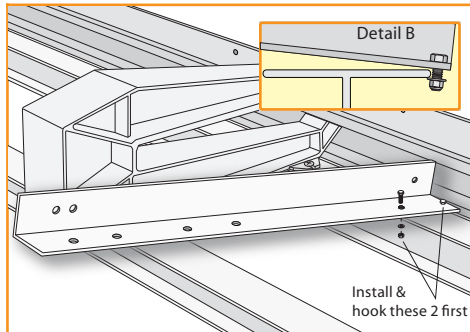

2 Insert hex head screw **C** down front hole **O** of right bracket **K**. From below, place washer **F** onto threads and start hex nut **G**. Lower front of bracket over base rail until washer **F** catches flange (see Detail B). Insert hex head screw **C** down rear hole of **O**. From below, place washer **F** onto threads and start a hex nut **G** to capture front base rail.

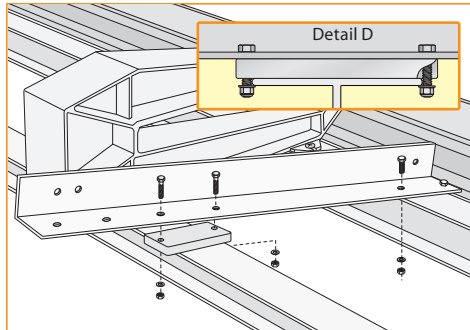

3 Position spacer **H** between bracket **K** and rail aligning holes. Insert hex head screws **D** down holes. From below, place washers **F** onto threads and start hex nuts **G** to capture rail (see Detail D). Repeat on opposite side of center casting with left bracket **J** then continue to step 4, page 3.

## TRIM-A-BRAKE I™

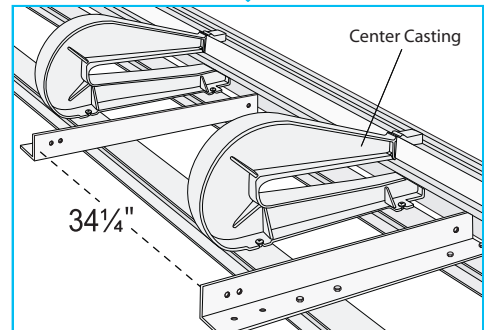

1 As seen in the mounting bracket above, use holes **O** and **Q** when mounting right bracket **K** and left bracket **J** on either side of the center casting.

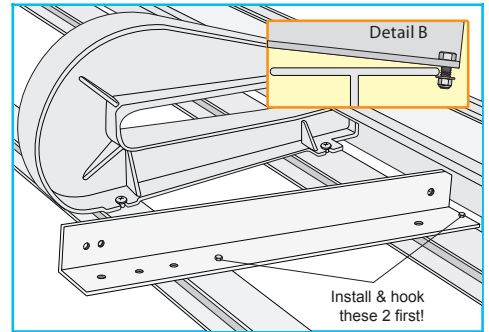

2 Insert hex head screw **C** down front hole **O** of bracket **K**. From below, place washer **F** onto threads and start hex nut **G**. Insert hex head screw **C** down front hole **P** of right bracket **K**. Again place washer **F** onto threads and start hex nut **G**. Place bracket over rails letting washers **F** hook over rail flanges (see Detail B).

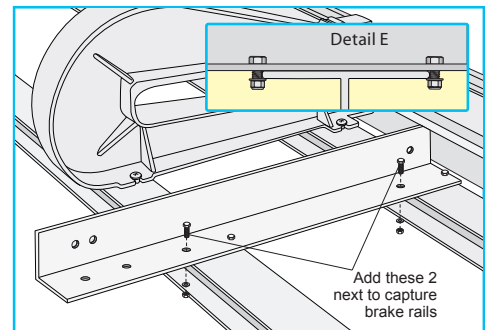

3 Insert hex head screw **C** down rear hole of **O**. From below, place washer **F** onto threads and start hex nut **G**. Insert hex head screw **C** down rear hole of **P**. Again place washer **F** onto threads and start hex nut **G**. As seen in Detail E, rail flanges should now be captured. Repeat on opposite side of center casting with left bracket **J**.

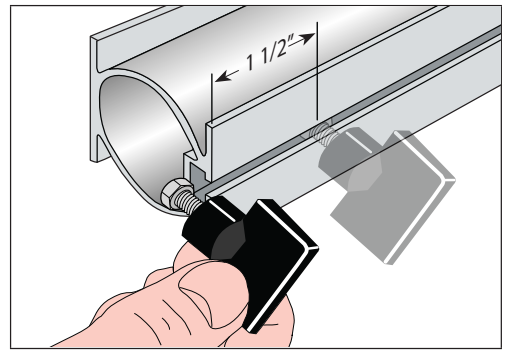
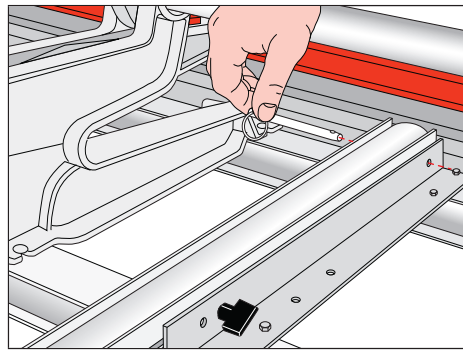
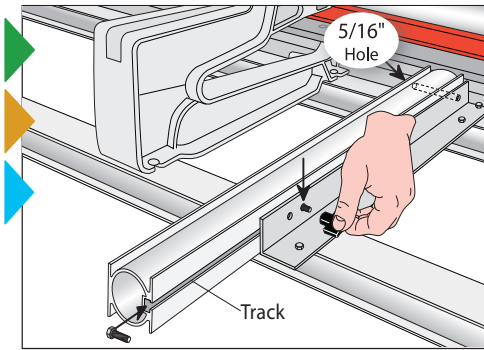

4 Place rail **L** alongside right bracket **K** with 5/16" hole to front of brake. Slide hex head portion of screw **D** down track and extend through 2nd hole from end of bracket **K** as shown (see center arrow). Start knob **F** onto threads and leave loose for now. Repeat this procedure with remaining rail **L** and left bracket **J**.

5 Align front hole in rail **L** with front hole in bracket **K**. Insert Fast Pin **A** through front hole in rail, then through bracket. Repeat this procedure with remaining rail **L** and bracket **J**.

6 Start knob **F** 2 or 3 turns onto the threads of a hex head screw **D**. Slide hex head portion of screw into track of rail **L** 1/2" and leave loose. Repeat this procedure with remaining rail **L**.

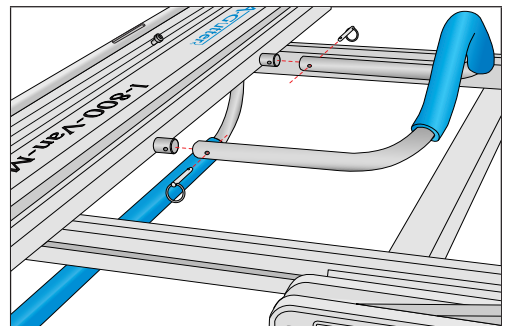
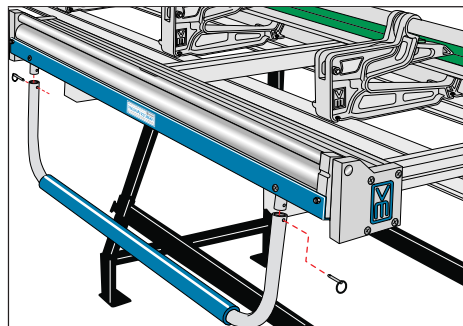
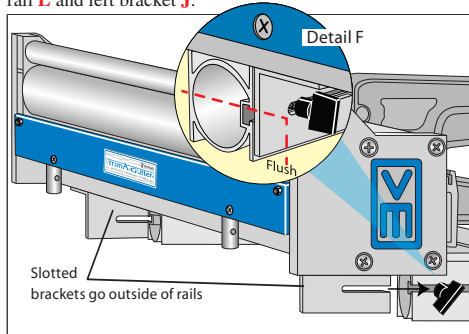

7 Ensure left & right rails **L** are 34 1/4" apart to receive the slotted brackets on bottom of tool. After aligning the slots with knob threads, slide tool onto rails until slotted brackets are **FLUSH** with ends of both rails (see Detail F). Tighten knobs on both sides. Ensure rails and brackets are positioned squarely on brake then tighten all fasteners, knobs **F** and locknuts **H** securely in place. Check all fasteners and knobs often and tighten as needed.

8 Install the roller handle over the handle plugs and insert short fast pins **B** through holes. Reverse procedure to remove handles when tool is being stored or transported.

9 To install the bending leaf handle, align holes in ends of tube with holes in handle plugs. Insert short fast pins **B** as shown.

### Metal Master® 20 Setup

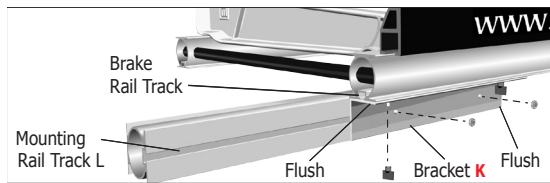

1 Slide two hex head screws **C** into tracks in bottom of brake rail. Extend bracket **K** over screw threads and tighten with knobs **E**. Ensure bracket **K** is **FLUSH** as shown. Slide two hex screws **C** into mounting rail track **L** and through holes in bracket **K**. Tighten firmly with lock nuts **G**. Repeat procedure on opposite side of brake facing away. Note: Use illustration below for assistance.

2 Start a knob **E** onto a hex screw **C** and slide into mounting rail track approximately 2 inches. Loosen slotted brackets from under tool and slide even with mounting rails keeping tool centered between the mounting rails. Slide the slotted brackets over the screws until **FLUSH** with mounting rails. Tighten knobs **E** securely. Now tighten lock nuts **G**. To remove tool, loosen knobs **E** and slide off from mounting rails.

Remove tool from brake before moving or transporting around job site. Do not lean on tool as tipping will occur causing injury or damage to machine.

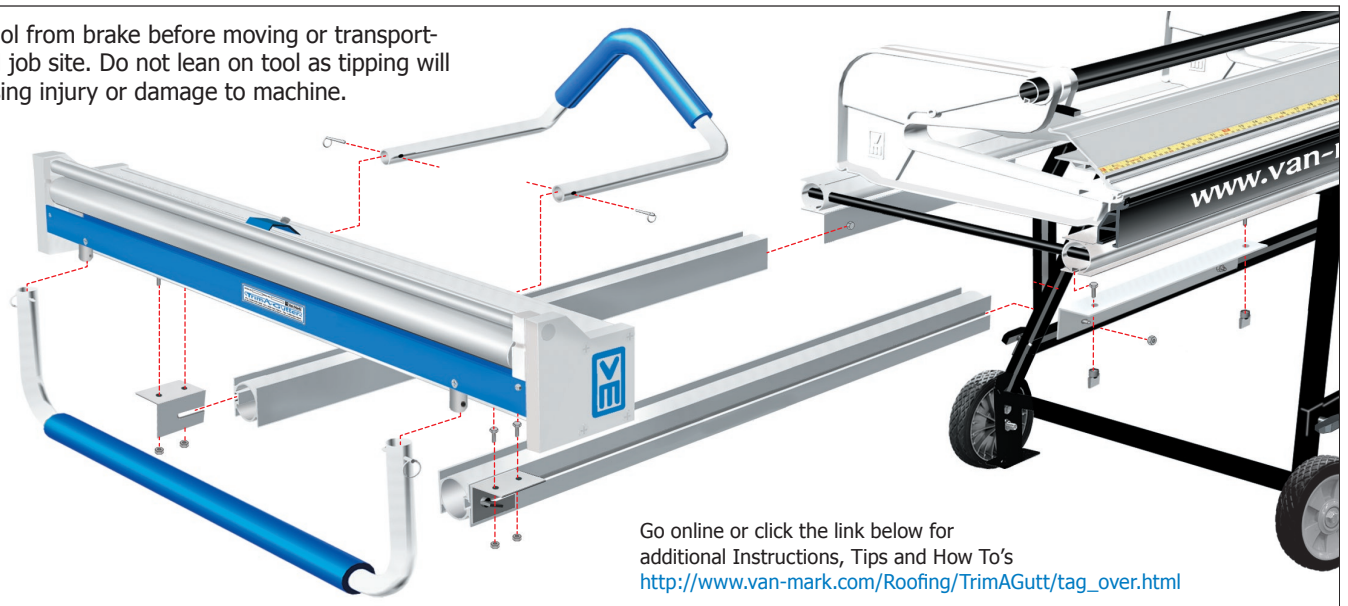

Go online or click the link below for additional Instructions, Tips and How To's  
[http://www.van-mark.com/Roofing/TrimAGutt/tag\\_over.html](http://www.van-mark.com/Roofing/TrimAGutt/tag_over.html)

3 Firmly tighten all knobs **E** and lock nuts **G**. Install the rolling handle and the bending leaf handle to complete the setup of the tool. Check the tool often for looseness and tighten as needed. Make sure the tool is free from dirt and debris which can damage tool and mar material. Do not lean against tool as tipping or damage can occur. Do not use the reinforcement clip when working with standard trim coil. Refer to step 4 Forming Gutter-Hood for instructions on using the reinforcement clip to make hood from stiffer gutter-coil material. Note: Except for the special instructions seen above for mounting Trim-A-Gutter™ to the wider 20" throat brakes, all other instructions should be followed.

## Tool Setup on UniLegs™ UNL1

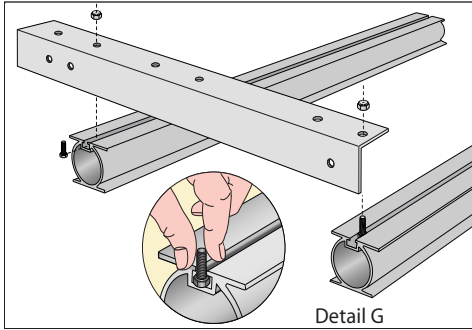

**1** Lay out rails **L** as shown with screw tracks facing up. Insert the hex head portion of screw **D** into each track (see Detail G). With bracket **K** facing downward, align holes (indicated by arrows), with hex head threads and lower into place. Tighten bracket snugly against rails with locknuts **H**.

**Caution:** To prevent the tool from tipping during use, always ensure the extended portion of the bracket is facing the same direction as the leg flare (see step 3 above). Always situate tool on level ground

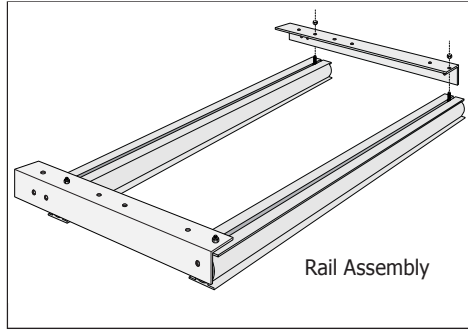

Rail Assembly

**2** From opposite end of rails, again insert the hex head portion of screw **D** into each track. Align holes in bracket **J** with hex screw threads and lower into place. Install locknuts **H**. Square up assembly and tighten all fasteners. Ensure all hole locations match those in drawing before proceeding.

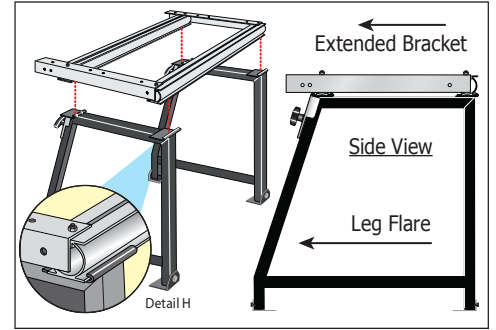

**3** Position a UniLeg™ at each end of rail assembly with the extended brackets facing the same direction as the leg flares (see Side View). Align rail flanges with retainer hooks on top of UniLegs™ and slide into place (see Detail H). Note: Ask for help holding UniLegs™ apart during this step if needed.

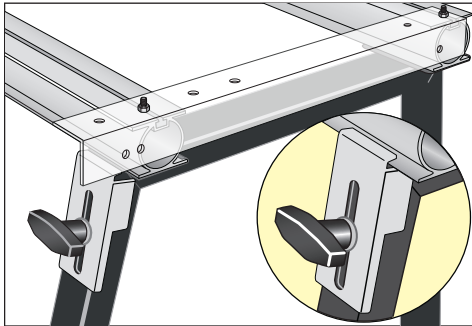

**4** To finish installing the rail assembly, loosen each **T** knob and extend latch plates up and over rail flange (see detail). Tighten **T** knobs snugly in place. Check **T** knobs often and tighten as needed.

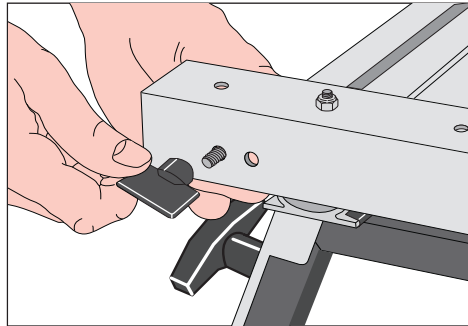

**5** Insert a hex screw **D** through the outward hole of the extended portion of the bracket **K**. Start a knob **F** several threads onto the hex screw **D** and leave loose for now. Repeat same procedure on opposite side of rail assembly.

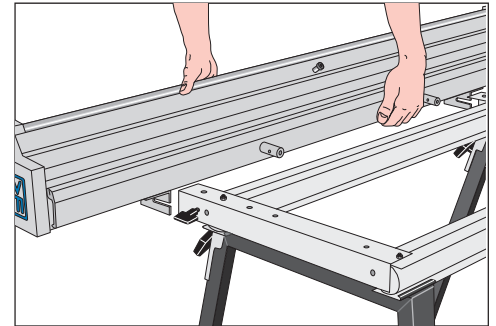

**6** Align slotted brackets on underside of tool to outside of extended brackets **K** and **J**. Align slots with hex screw threads and slide in place to a complete stop. Tighten knobs **F** snugly. Install handles referring to Steps 8 & 9 above.

## Forming Gutter-Hood

**Note:** General knowledge in the installation of gutters and/or roofing field will be very helpful in using these guidelines. Please take time to read this User Guide before getting started. In this section, we will show how to form basic gutter-hood from standard trim coil.

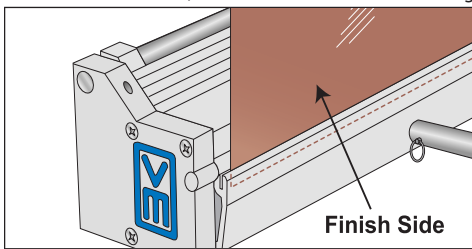

**1** Cut a blank up to 50 inches long and to the desired width. Insert edge fully into slot with finish side (the side exposed to the weather), facing as shown. Bend upward 90° to create a 1/2" flange.

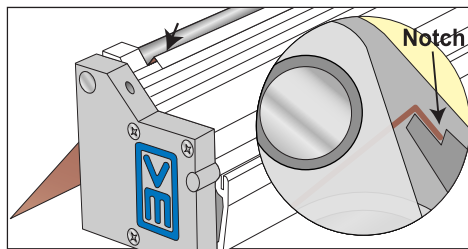

**2** With finish side of material facing downward, slide flat end between roller and anvil until the 1/2" flange is fully seated in notch. Note: The 1/2" flange must be exact to work properly with brackets.

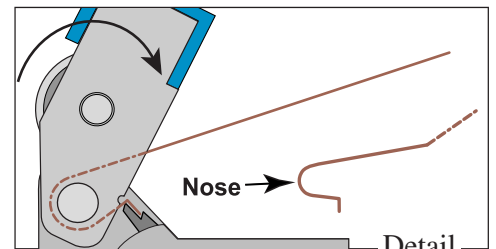

**3** Lift roller handle to a complete stop to form the radius. Note: When forming standard trim-coil, use of the reinforcement clip (step 4), is unnecessary.

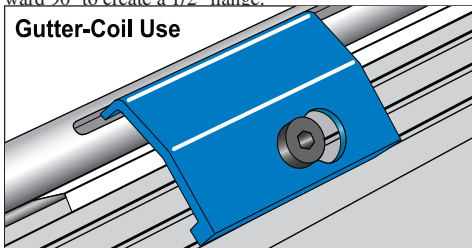

**4** For gutter-coil, insert blank per Step 2 above and slide reinforcement clip in place. Lift roller handle to form radius without allowing blank to touch or hit the clip which can cause damage to material.

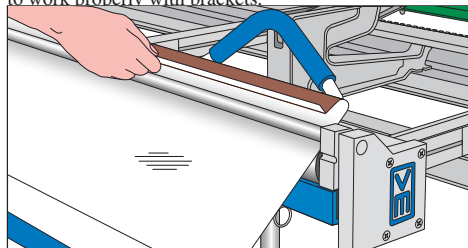

**5** Return roller to the starting position and remove reinforcement clip if in use. Rotate blank and slide from tool. Note: Practice with smaller lengths until satisfied with results.

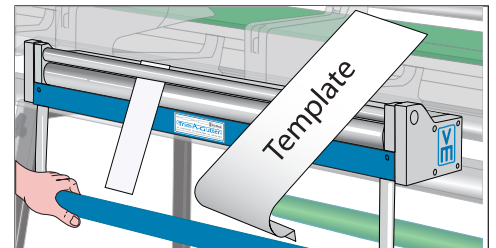

**6** Cut a 3" or 4" strip and perform steps 1, 2 and 3 above. This will become your template to use throughout the job and will be further explained in the following steps below.

**Pre-Installation Note:** Most trim/gutter coil comes from the factory with a glossy, or shiny finish which can cause rain to overshoot the gutter opening (similar to water running off a waxed car). This is a common occurrence in the gutter/leaf protection industry and should be discussed with the property owner. Normally, the gutter-hood loses its shiny finish after a short time of exposure to the elements with the water then wrapping around the gutter-hood and falling into the gutter trough the way it's supposed to. One solution, for those who don't want to wait for Mother Nature to do her thing, is to remove the shiny finish on the gutter-hood surface by lightly wiping it with a Scotch-Brite® type pad so it dulls the surface slightly. This should allow the water to properly adhere to the gutter-hood until it is deposited into the gutter trough. Note: Scotch-Brite® is a registered trademark of the 3M corporation.

## Existing 5 & 6 inch Gutter Installation 5-

The following instructions are to be used as a guideline on getting up and running with Trim-A-Gutter™ Tools and Hardware. Before getting started, it is recommended that you check the entire gutter system for problems, such as clogged downspouts, leaks or rotted wood, before installing gutter-hood. Use these guidelines for installing new 6" brackets as well. Check end caps, outlets and seams for water-tightness. Keep in mind Trim-A-Gutter™ gutter-hood will not make the gutter system waterproof, only leaf resistant.

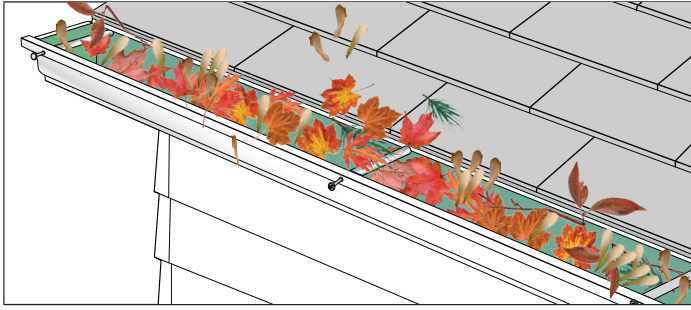

**1** Clear all leaves and debris from gutter and downspouts. Check entire gutter system for loose spikes/seams and miters. Other problem areas, such as improperly installed gutters and downspouts should be corrected before installation.

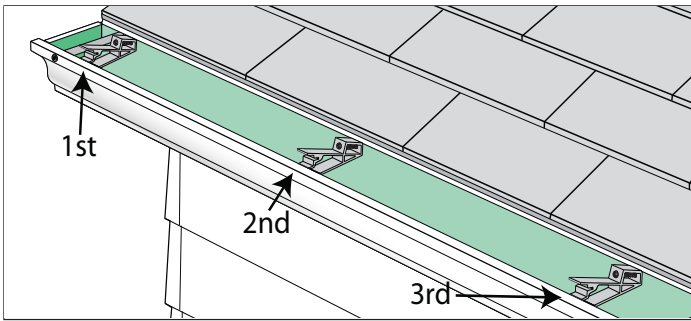

**3** Install second bracket approx. 24" from 1st. Install 3rd bracket 1/2" in from end of the first gutter-hood section. This bracket will also serve as the 1st for the next section of gutter-hood which will overlap the 1st (or under depending upon prevailing wind direction). Note: For extreme weather conditions, install additional brackets.

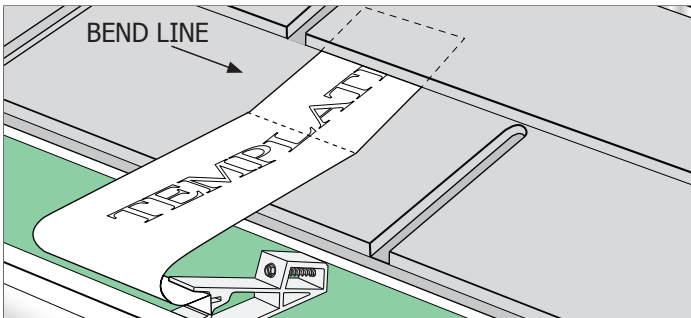

**5** Situate the template into bracket and onto roof area. Mark point in template where you want to match roof pitch (as shown), and make bend. The area below the bend line must maintain a slight pitch for positive drainage.

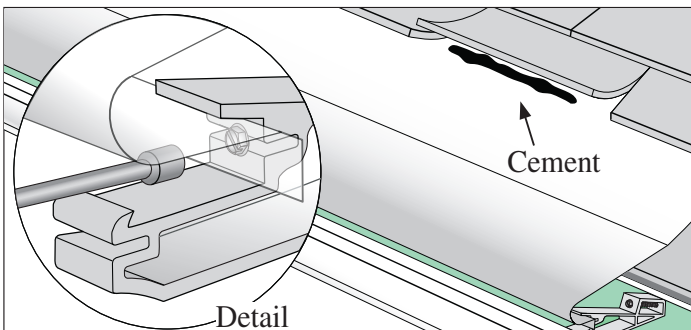

**7** Tuck top of gutter-hood under loosened shingle tabs and fasten 1/2" flange into first 2 brackets using 3/8" stainless screws (see Detail). Leave the 3rd bracket free until next section of hood is lapped. Reseal shingles by applying a bead of roof cement under each tab. Allow tabs to fall back in place ensuring no roof cement is visible, or exposed.

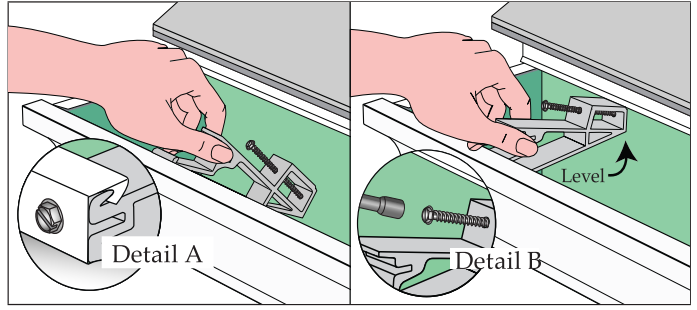

**2** Pre install anchor screw into bracket. Near the gutter end-cap, lower back of bracket into gutter and insert front into gutter channel until hook catches lip (Detail A). Next, lift bracket until bottom is level. Hold firmly in place and drive anchor into fascia (Detail B). Note: If loose or no lip exist in channel, install 3/8" stainless screw thru channel and into slot (Detail A).

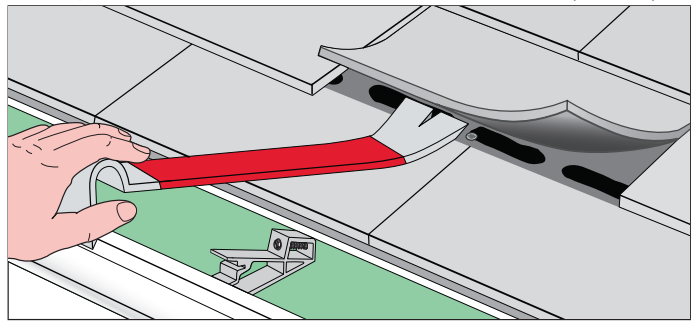

**4** Carefully pinch up the tabs along the course of shingles the gutter-hood will be going under. To prevent puncturing/breaking the shingle tabs, work the pinch bar side to side as opposed to up and down. Note: Care should be given to older shingles which become brittle over time.

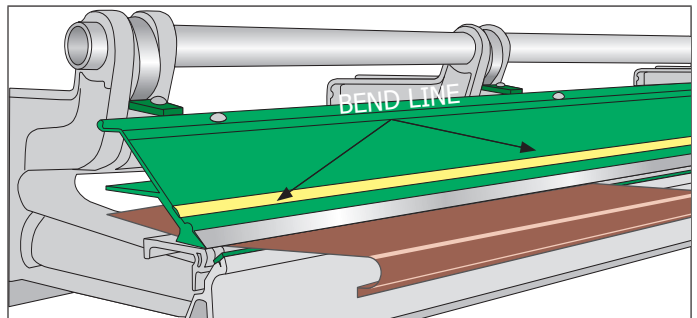

**6** After forming gutter-hood, transfer bend line from template onto piece. Place piece into the brake aligning the bend line with the stainless edge. Bend upward until the piece matches the template to create the first section of gutter-hood.

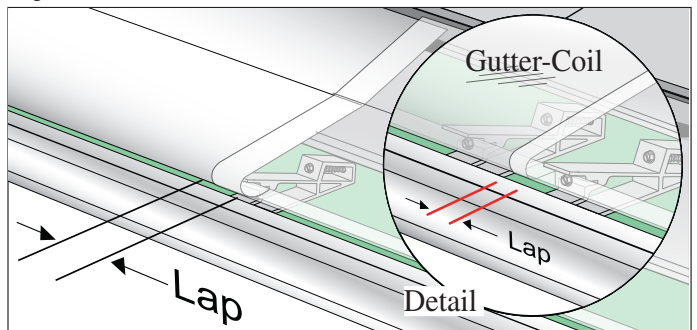

**8** Lap the next section of gutter-hood over/under the 1st section to a point where both ends are centered over a bracket. Install the 3/8" stainless screw thru lap and into bracket. With your template, continue installing brackets and sections in this manner until complete. Note: When using gutter coil place lap between 2 brackets (see Detail).

# Universal Template for 5 & 6 inch gutters

\*To download a splash or end-cap template, go to [www.van-mark.com](http://www.van-mark.com) and navigate to the Trim-A-Gutter™ Installation page. Scroll down and click either the splash or end-cap image.

7.40"

Left or Right Template  
Cut out pattern and transfer template to material. Cut along lines & adjust tabs to fit gutter and hood as no two are alike. Use cover-screws to secure template in place. For 6 inch, extend template approximately 1 to 2 inches.

© 2012 Van Mark Products Corp.

## End Cap, Miter & Valley Construction

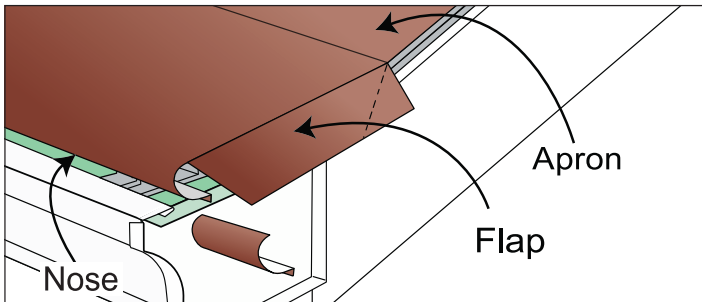

**O**ption 1. Install gutter-hood 2-3 inches past end of gutter. Cut away the nose portion extending past the end cap. Trim the excess apron to edge of roof. Bend flap downward 90°, and trim along roof edge.

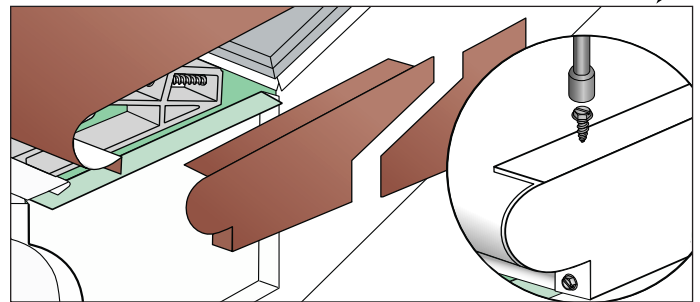

**O**ption 2. Use template\* (above), to transfer dimensions onto material. Trim and bend piece to fit profile. Bend flange 90° and install a 3/8" self-drilling stainless screw at each end and bottom tab.

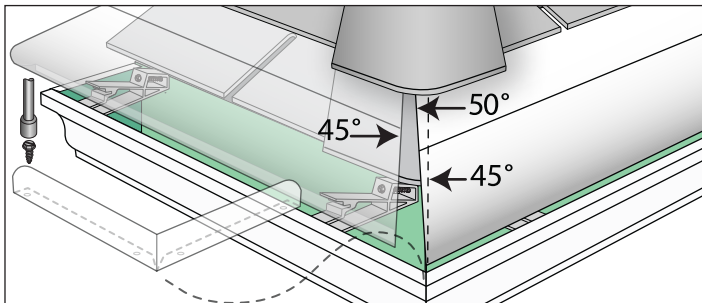

**M**iter. For hip roofs or returns, trim 1st section 50° and 2nd 45°. Butt the two sections along miter line. The extra 5° is used to conceal any gap between the miters and can be bent over to fit the contour of the ridge caps. Slide top edges under ridge cap. Once satisfied, fasten sections into brackets. Install splash guard\* using 3/8" self-drilling stainless screws.

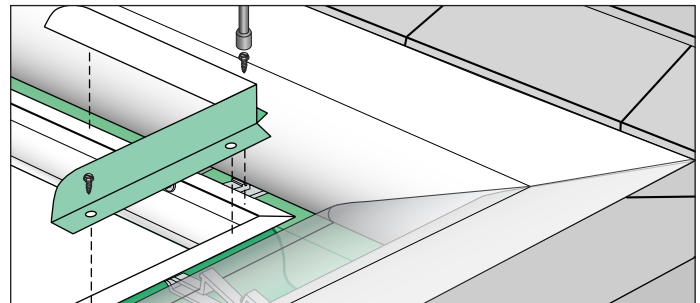

**V**alley construction will vary from job to job. For typical installation, run 1st section past the miter line and trim the next piece even with the miter line. To prevent water run-off, add a splash guard\* as shown using 3/8" self-drilling stainless screws.

Two common installations for Trim-A-Gutter™ are fascia and roof mount. What style you use will depend on preference and job dimensions. Use these details as a guide in choosing. Note: It is the responsibility of the installer to ensure work conforms to building code and sound gutter/roof installation practices.

## New Gutter Installation-Fascia Mount

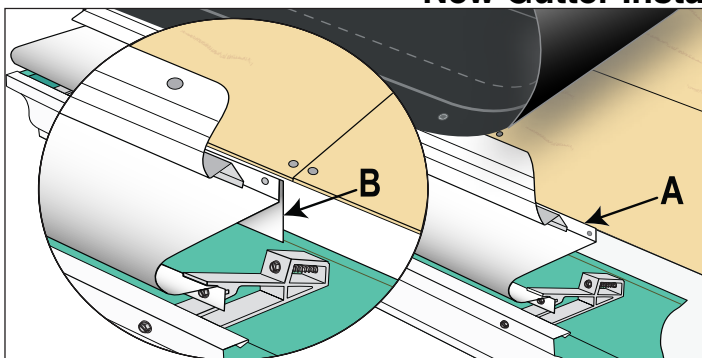

**1** Hang gutters as you normally would using Trim-A-Gutter™ brackets & anchor screws. Design gutter-hood to terminate either at the top of fascia with a 90° flange (A) leaving room for drip edge, or (B), make bend 180° downward leading into gutter. Create a template of your profile as previously explained. Follow steps 2-8, as they apply, in the Existing Gutter Installation section.

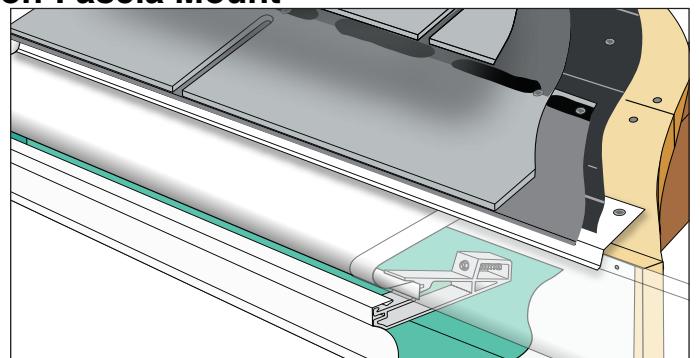

**2** Next, install drip edge, underlayment and roofing per manufacturers instructions. Note regarding miters and end-caps: Due to the wide range of applications seen in residential gutters and roofing, it would be virtually impossible to outline detailed steps for making and installing them all here. We recommend using scrap to make practice bends until you are satisfied with your results.

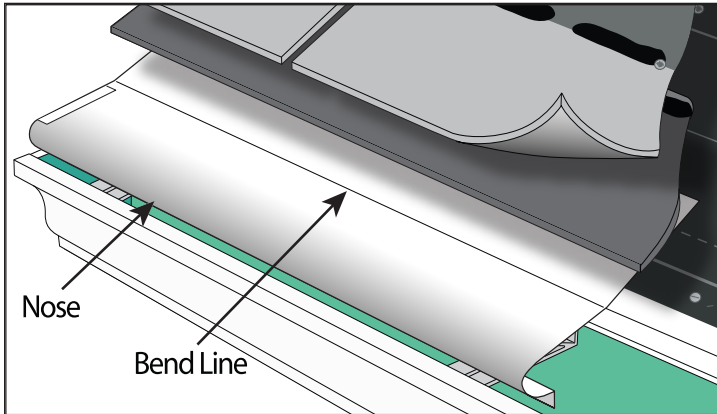

**L**ow Profile. Install gutters using brackets & anchor screws. Create a template based on this profile remembering to keep a downward pitch from the bend line to the nose. Install drip edge and underlayment, then sections of gutter-hood based on your template. Install shingles even with bend line. Note: You may install hood under the 1st course of shingles provided the gutter is low enough to maintain the downward pitch from the bend line to the nose.

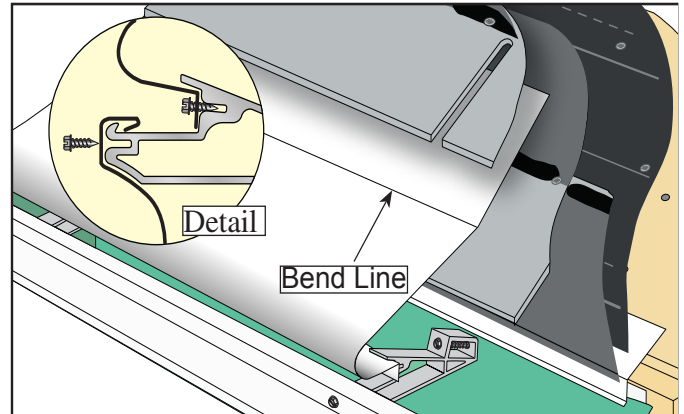

**D**ome Profile. Install 1st course of shingles. Determine whether gutter-hood will go under the 2nd or 3rd course of shingles. Create a template of this profile and mark your bend line as previously described. With this particular design being more visible, match the gutter color as closely as possible for seamless integration.

Common Roof/Gutter/Fascia Profiles

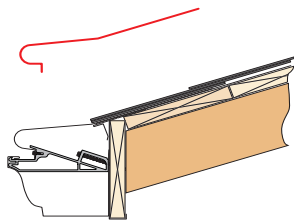

3/12 Pitch-Under Shingle

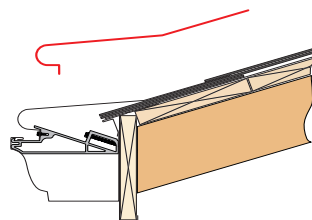

3/12 Pitch-Over Shingle

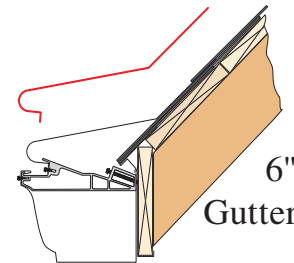

12/12 Pitch-Over Shingle

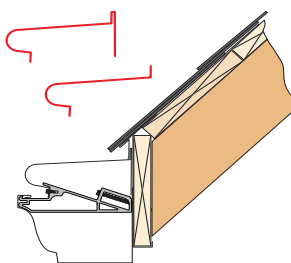

12/12 Pitch-Fascia Mount

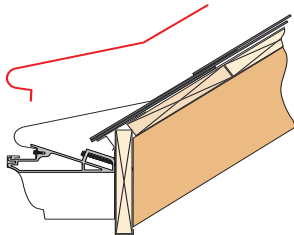

8/12 Pitch-Over Shingle

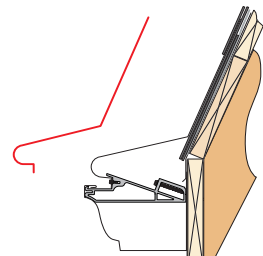

18/12 Pitch-Mansard

Example Side Elevation

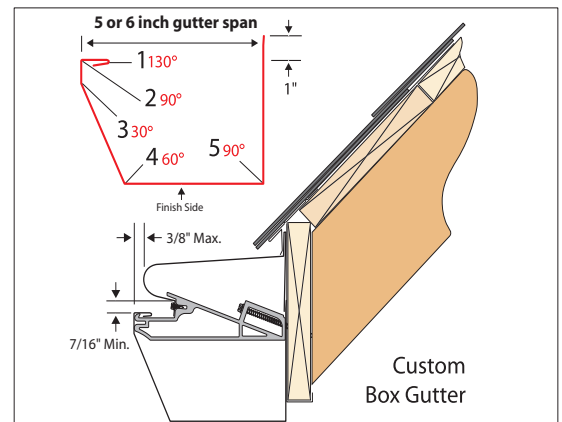
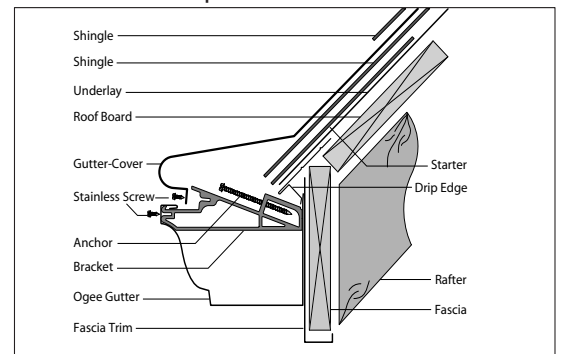

1. Insert blank 1/2" into brake, lock in place. Bend 130° (max. bend on brake).
2. Remove from brake, turn around and reinsert to 3/4", lock in place. Bend 90°.
3. Unlock brake and slide out 3/4", and re lock. Make bend 30°.
4. Unlock brake and slide out approx. 3". Make bend 60°.
5. Unlock & slide out approx. 3.5 to 4". (to achieve 5" bracket span). Bend 90°.

Care & Maintenance

Your new Van Mark tool has been calibrated and adjusted at the factory and is ready to go. Follow these steps for optimum performance and installation of gutter-hood.

The Trim-A-Gutter™ TAG50 Tool

Installation Tips

1. When mounting to your Van Mark brake, always ensure brake is level on stable footing.
2. Never lean or place weight on tool once mounted as tipping can occur.
3. Keep bending leaf hinge and slot free from debris (no. 17 & 23 on your parts list).
4. Always remove tool from your brake before transporting to and from the job site.
5. Check all fasteners and knobs often and tighten as needed.
6. Clean and lubricate tool with light spray-lubricant before use, or as needed.
7. Keep hands and fingers away from moving parts while setting up and using tool.
8. Never expose tool to rough loading/unloading, bumps and knocks as damage will occur.
9. For balance, always mount tool as close to the center of the brake as possible.

1. For best results, use a screw gun with adjustable torque settings.
2. Pre install anchor screw into bracket until barely visible out the back.
3. Hold bracket firmly in place while driving anchor screw into fascia.
4. Do not over-torque anchor screws and cover screws which can twist off heads.
5. Do not set ladders against nose of gutter-hood as slipping or damage can occur.
6. Ensure you have adequate amount of brackets and anchor screws before starting job.
7. For added durability and strength, increase the amount of brackets per section.
8. Form gutter-hood blanks (without the roof pitch bend), at the shop between jobs.
9. Download & print sales literature from Van Mark's web site for customer presentations.

Although Van Mark undergoes extensive research on all our products, including the Trim-A-Gutter™ gutter-hood forming tool, it is the sole responsibility of the user for the correctness of installing gutter-hood to any gutter, fascia and/or roofing system, whether new or retrofit construction. Use the instructions provided here, including the following profiles, as an example on getting started with Trim-A-Gutter™. Van Mark cannot be held liable for any damages arising from the installation of gutter-hood, hardware, gutter, fascia and/or roofing. As with other Van Mark tools, we recommend that you make practice shapes with scrap until satisfied with your results.

For Quick "Same Day Shipment" Order Early





Order Toll-Free 24 Hrs Call Free 1-800 Van Mark Fax Free 1-888 Van Mark

Ref	Description	Qty	Part No
1	End Block Screw	8	2067
2	Anvil Lock Screw	4	2014
3	Anvil Bracket Screw	1	2010
4	Lower Rail Screw	2	2064
5	Roller Tube Bearing	2	4604
6	Roller Support Bearing	1	4605
7	Support Bearing Screw	1	2049
8	1/4 x 1" Fast Pin	4	2710
9	Stainless Steel Anvil	1	4606
10	Roller Tube	1	4608
11	End Block	2	4610
12	Pivot Block	2	4611
13	Lower Rail	1	4612
14	Roller Axle	1	4614
15	Bearing Bracket	1	4617
16	Reinforcement Clip	1	4616
17	Body	1	4618
18	Name Plate	1	4628

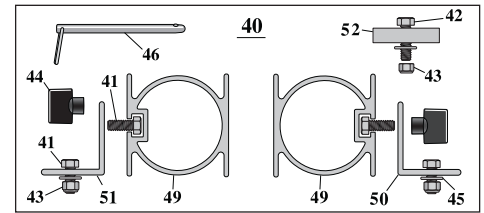
Ref	Description	Qty	Part No
21	Roller Handle	1	4053
22	Roller Handle Grip	1	4625
23	Bending Leaf	1	4620
24	Leaf Handle	1	4622
29	Bending Leaf Stub	2	4623
30	Roller Handle Stub	2	4110
33	Anvil Spacer	2	4631
34	Leaf Handle Grip	1	4626
35	Bearing Brkt. Screw	1	2053
36	5/16" Flat Washer	2	2505
37	Roller Stub Screw	2	2006
38	Leaf Stub Screw	2	2070
39	5/16" Lock Washer	2	2504
41	1/4-20x5/8 Hex Hd	36	2058

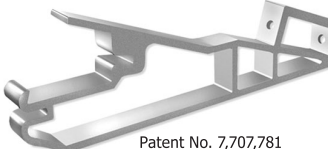
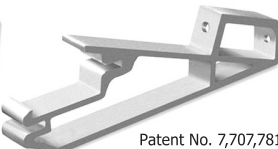
Ref	Description	Qty	Part No
40	UniMount™ Assembly	1	3097
41	1/4-20x5/8 Hex Hd	13	2058
42	1/4-20x1 1/4 Hex Hd Cap	4	2071
43	1/4" Nyloc Nut	16	2313
44	Lock Knob	4	2072
45	1/4" Flat Washer	8	2512
46	5/16 x 2 1/2" Fast Pin	2	2715
47	3" Right Body Bracket	1	4632R
48	3" Left Body Bracket	1	4632L
49	Rail	2	4634
50	Right Bracket	1	4633R
51	Left Bracket	1	4633L
52	Spacer	2	4635



<p>PN4637 6" Bracket Available in 100 and 500 pc kits</p>  <p>Patent No. 7,707,781</p>	<p>PN4630 5" Bracket Available in 100 and 500 pc kits</p>  <p>Patent No. 7,707,781</p>	<p>PN2069 3" Anchor Screw Available in 100 and 500 pc kits</p> 	<p>PN2068 Cover Screw Available in 100 and 500 pc kits</p> 	<p>PN4629 Bit Driver</p> 	<p>UniLeg™ Supports</p> 
---	---	--	--	--	---

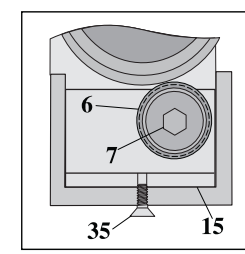
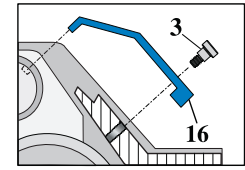
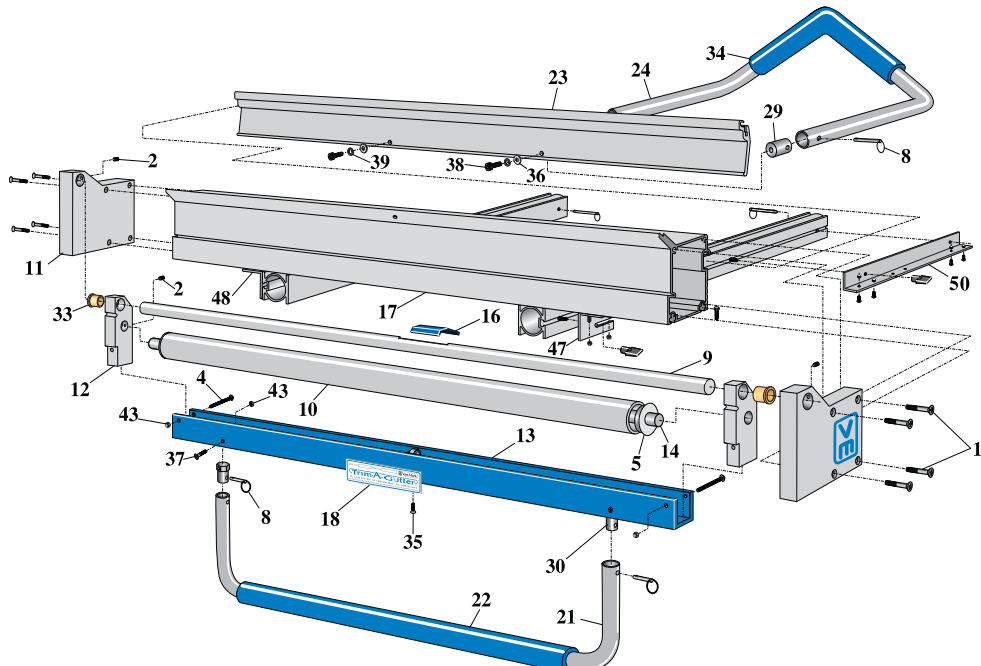

Trim-A-Gutter™ TAG50

Scan with Smart Phone



Trim-A-Gutter™ Online

VAN MARK PRODUCTS CORPORATION

24145 Industrial Park Drive, Farmington Hills, MI 48335-2864 Michigan 1-248-478-1200  
 Call Free 1-800-VAN-MARK (1-800-826-6275) Fax Free! 1-888-VAN-MARK (1-888-826-6275)  
 Web Site: <http://www.van-mark.com> E-mail: [sales@van-mark.com](mailto:sales@van-mark.com)  
**Note: Price subject to change without notice. Call for current prices before quoting.**